

CONTINENTAL

PIPE & TUBE CUT-OFF MACHINES
WE MAKE THE CUT - FAST & CLEAN

MIST LUBRICATION KIT

AVAILABLE FOR NEW AND EXISTING MACHINES!

Continental is proud to introduce the Model 310 Mist Lube system for Model 2A, 3A and 6A machines.

Continental pipe and tube cutoff machines cut most tube with no lubrication. However, lubrication will improve cutting speed and blade life. The Model 310 lube unit applies minute amounts of lubricant directly to the blade. This near-dry method improves cut speed and blade life, while creating almost no mess. In many cases, it also improves the cut itself by reducing end roll-in and burr formation.

The Model 310 is available as a retrofit kit for your existing Continental machine.

Adjustable position accommodates
a wide range of blade diameters

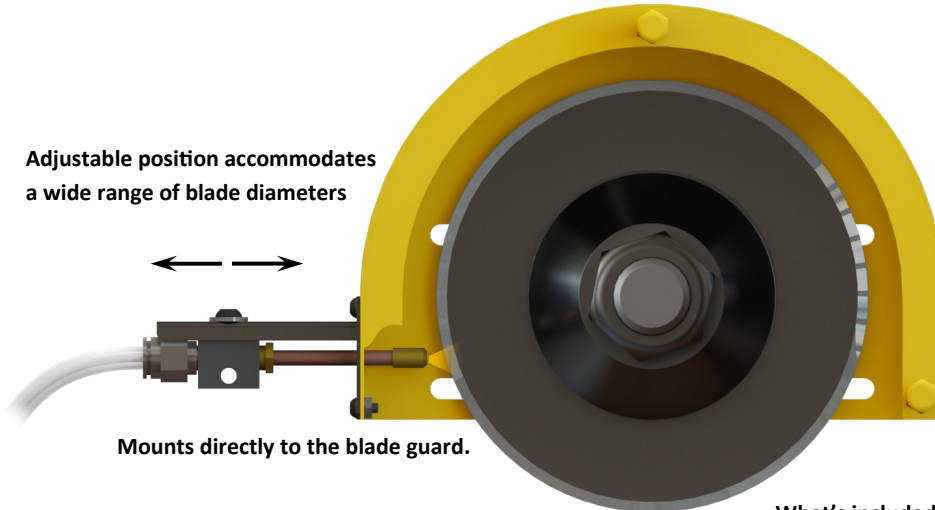

Mounts directly to the blade guard.

- **Increased blade life**
- **Reduced cutting time**
- **Easy to install and set up**
- **Cleaner cuts and reduced burr**
- **100% natural and biodegradable lubricant**
- **Minimum lube usage means no mess and less cost**

What's included:

Pump enclosure and mounting plate
Spray nozzle, hose, and mounting bracket
Pneumatic fittings and tube
Wiring kit
Fasteners



Ordering Information:

MODEL 310 Option for new Continental machines
MODEL 310-RFK Retrofit kit for existing Continental machines

Call for information and pricing!
(800) 264-5950